

View Single Post

Thread: [Stereo Information \(Wiring, Upgrades, etc...\)](#)

06-17-2015, 08:46 PM

#1

[smdandb2](#)

ManBearPig



Drives: 1998 CV HPP

Join Date: Oct 2014

Location: Uranus

Posts: 721

Thanks: 157

Thanked: 359 Times in 175

Posts

Mentioned: 8 Post(s)

Tagged: 0 Thread(s)

⚠ Stereo Information (Wiring, Upgrades, etc...)

I figured this information is kind of scattered everywhere, so I am trying to condense it all into one place to help everyone out.

If there is information that needs to be edited or added, let me know. Hopefully I will be able to edit this later to keep it up to date.

Speaker Info

Base Model (6 Speaker Configuration)

6.5" (Doors)

Tweeters (A Pillars)

6.5" (Rear Deck)

Premium Models 200A/400A (9 Speaker Configuration)

6.5" (Doors)

3.5" (Doors)

Tweeters (A Pillars)

3.5" Center Channel (In dash)

6.5" (Rear Deck)

Premium Models w/ Shaker Audio 201A/401A (12 Speaker Configuration)

6.5" (Doors)

3.5" (Doors)

Tweeters (A Pillars)

3.5" Center Channel (In dash)

6.5" Coax (Rear Deck)

Subwoofer

Speaker Pictures (Premium Shaker Shown) - *Thank you stoli!!*







Amplifier Information

Base cars do not have an amplifier, all speakers are powered directly from the head unit.

Premium/Shaker cars have an amplifier in the drivers side kick panel area that is driven from line level feeds from the head unit. The center channel is "created" by the amplifier itself, not the head unit. The sub signal also seems to be artificially created as I see no wiring to suggest it comes directly from the head unit.

The subwoofer amplifier is located on the subwoofer box itself.

Wiring Information

Here are the wiring diagrams for the cars. *Thank you Heinoceros.*

Base radio (only shows front speakers):

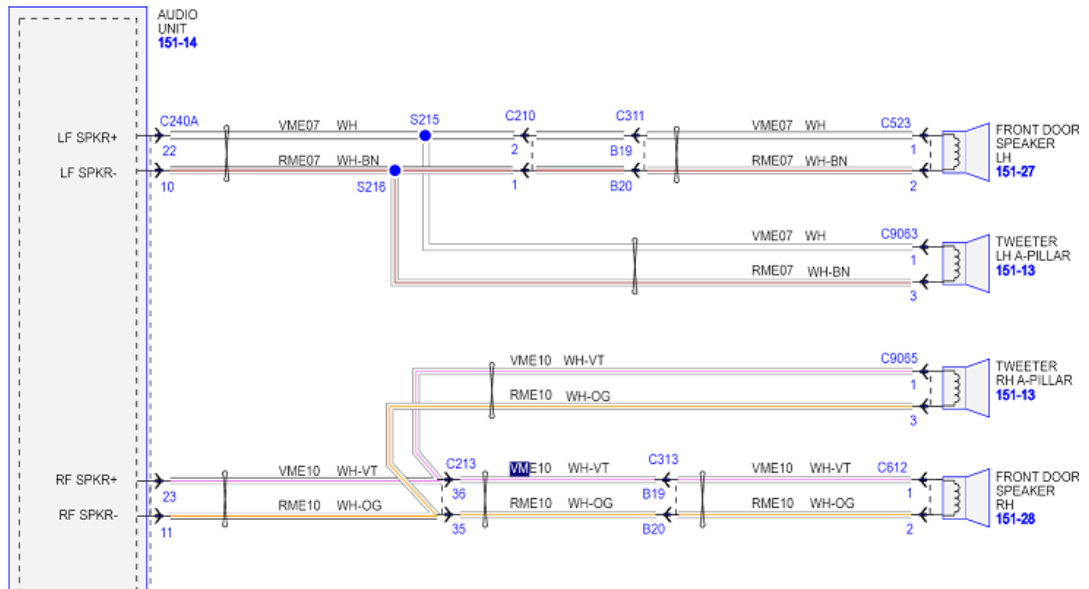

Premium (including Shaker systems):
Head Unit to Amplifier



Amplifier to Speakers

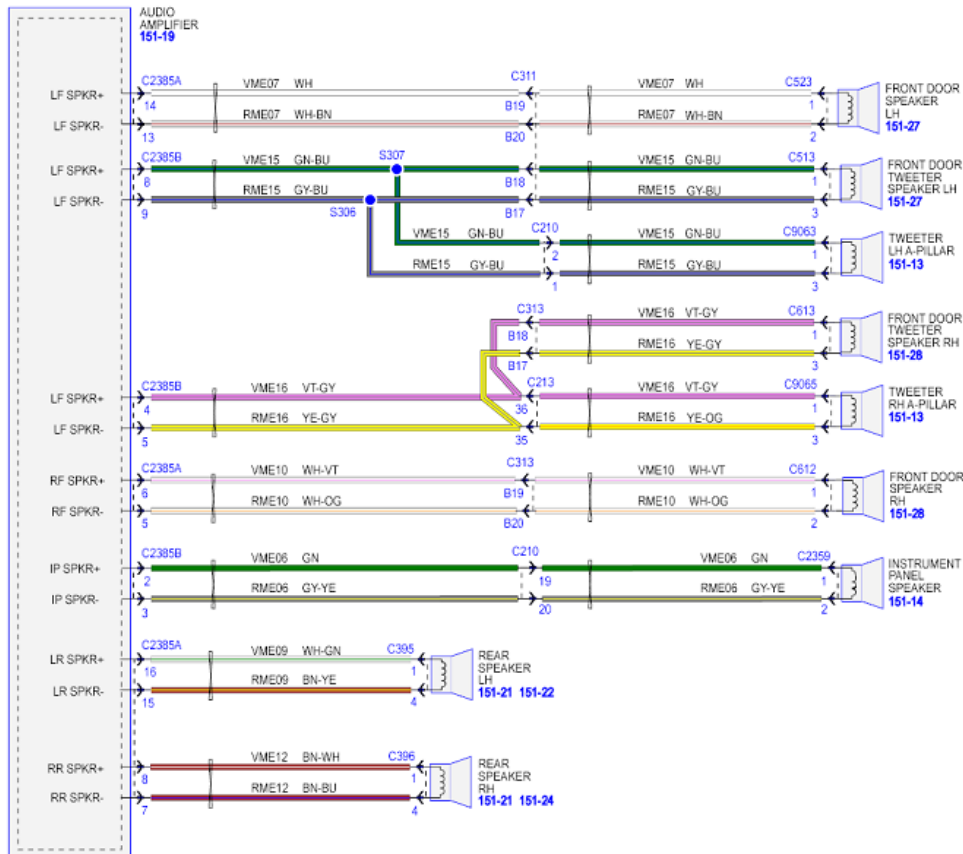

Amplifier Connectors Thank you *ThirtyThreePointThree* and *h65* for getting part numbers and the rest of this information.

These are made by Molex and can be had from Mouser.com.

34690-0160 - C4270 has the RCA-level audio and noise cancellation.

<http://www.mouser.com/Search/Product...x?R=34690-0160>

34690-0161 - C2385A has most of the speaker outputs.

<http://www.mouser.com/Search/Product...x?R=34690-0161>

34772-0142 - C2385B has the other speakers plus 6v Remote, 12V power and ground. Mouser does not stock the 34772-0142 plug so use the 34772-0140 variant. To use this you'll need to trim the bumps off the factory end. They come off easily with a boxknife. This is easier than trimming the inside of the new connector. It won't affect its ability to lock in place with the amp or the new connector.

<http://www.mouser.com/Search/Product...x?R=34772-0140>

Pre-Amp Signal Measurements - Thank you *h65*!

The range is 0.04 volts at 20% volume to 1.53 volts at 80% volume (and 3.1 volts at max volume) with a CD audio source. Measurement was taken from pins 7 and 8 which represent the front left signal.

12v Remote Turn-on Lead

There is one conveniently located in the trunk wiring harness near the right rear speaker. The wire you are looking for is the blue/white one.

Justin

2015 Mustang EcoBoost Premium

Magnetic/Dark Saddle • 6MT • PP • NAV • GT350 Steering Wheel • Vargas Stage2 • Tune+ • cp-e Catted Downpipe • Tomei Expreme Ti Exhaust • COBB Intake • cp-e Race Core • Volk Racing G25 Prism • Eibach Pro-Kit • Anderson Composites CF Trunk with Integrated Spoiler • Hertz Mille • Hertz HDP4 x2 • JBL MS-8 • Dayton Audio Sub • EcoBoost Smoke Mod

2002 Exploder V8 4x4

Stock, for now.

Last edited by smdandb2; 02-20-2017 at 05:10 PM.

user: offline

quote Thanks

Users thanking this:

[09jsw](#), [1QwkEcoBoost](#), [350Mike](#), [Alloye](#), [BigEasyGT](#), [Bryman](#), [BubbaMc](#), [Cars_1959](#), [Charles147](#), [Clink](#), [Cobra Jet](#), [ConspicuousConsumption](#), [Crais](#), [davekro](#), [diagnostiker](#), [Dirtleg](#), [djcwardog](#), [drbrian722](#), [DrEverettScott](#), [dwaleke](#), [DWC_SmOziLLa](#), [e30og](#), [EcoBOSS](#), [Edwin](#), [Ericc B](#), [FeedtheNeed](#), [garage34](#), [Gnome](#), [GoldnAzn](#), [Husker](#), [JayTea](#), [Ieszek](#), [Mattitude](#), [MDRN](#), [mikes2017gt](#), [Mjolineer](#), [MotorJoe](#), [Mustang365](#), [NewSVO](#), [POOPonYOU](#), [PR78](#), [proamas](#), [ProjectWhitemare](#), [Reaper](#), [Redcruzer](#), [rigrage](#), [Sauron_EH](#), [Schoony](#), [scott_0](#), [Souldriver](#), [stangmeister](#), [stingerbtry](#), [StoneRT](#), [terryrwood](#), [turtleboy](#), [Volstang](#), [VoodooShelby](#)

Close this window